

AYVAZ-CAD/ Resim üzerinden ölçü almayınız.
AYVAZ-CAD/ Do Not Take Measurements From The Drawing

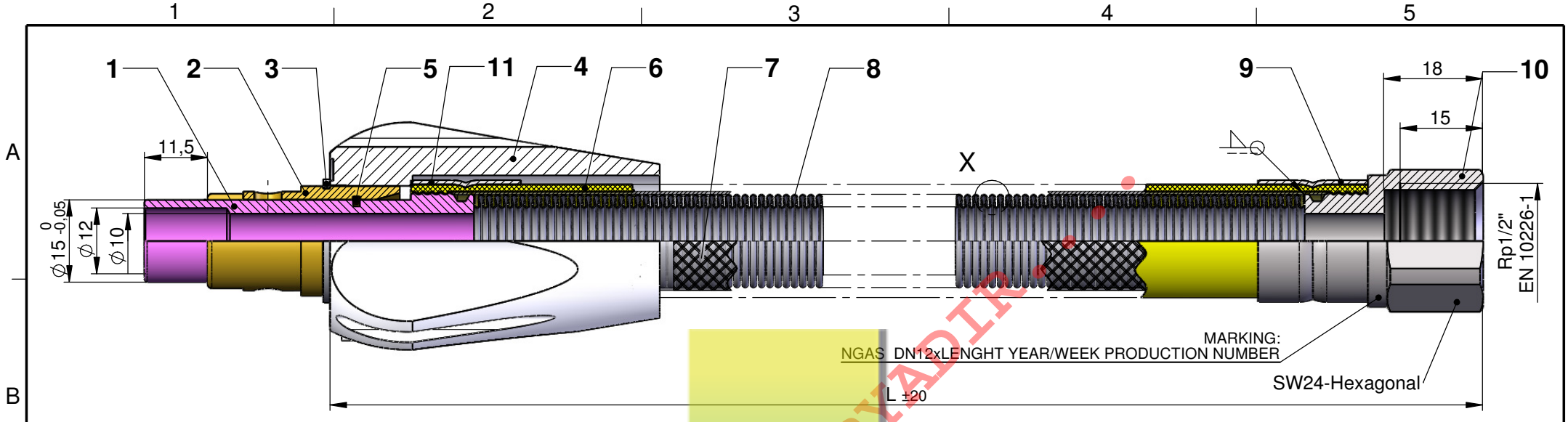

PVC MARKING:
EN14800 -TYPE1-NATURAL GAS-CE 0085 DN12

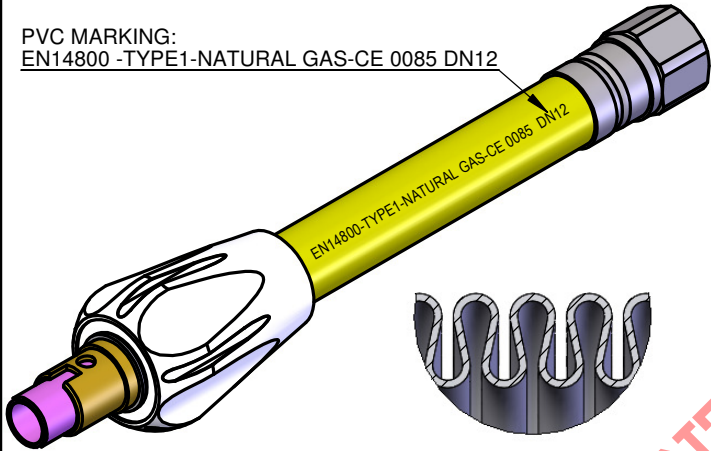

X (5 : 1)

No Item	Ad. Qty.	PARÇA ADI / Part name	MALZEME Material	ÖLÇÜ Size	RESİM NO Drawing No	AÇIKLAMA Explanations
11	1	Band	1.4301	DN12	601.080.100.260	
10	1	Raccord	AISI 303/304	1/2"xDN12	601.130.101.152	
9	1	Band	1.4301	DN12	601.080.100.265	
8	1	Hose	1.4404	DN12	601.009.215.047	
7	1	Braid	1.4301	0,30x3		
6	1	Cover	PVC	DN12		
5	1	Spring Ring	1.43010	Ø16,2x1	601.130.101.030	
4	1	Handle	Polyamides			H30KEN016
3	1	Spring Ring	1.4310	Ø19,1x1,2	601.130.101.000	H30KEN017
2	1	Internal Part	CW614N +CrNi Coated	DN12		H30KEN004
1	1	Welding End	1.4301	DN12	601.130.101.142	H30KEN011

L	Product no
500	701.150.153.050
750	701.150.153.075
1000	701.150.153.100
1250	701.150.153.125
1500	701.150.153.150
2000	701.150.153.200

Isim / Name	Tarih / Date	İmza / Signature	Ölçek Scale	
Çizen / Drawer	A.SEZGİN	13.10.2016	1:1	
Kontrol / Control	E.ÖZKAN	13.10.2016		
Onay / Approval	İ.COŞAR	13.10.2016		
Parça Adı / Part Name	EN 14800 - TYPE 1 NATURAL GAS - DN12			
Ürün Tipi / Product Type	14800			
Müşteri Kodu / Customer Code		Malzeme / Material	Miktar / Qty.	Ağırlık / Weight
Firma Resim No / Firm Drawing No				
Item No	701.150.153.000			
CAD No	H02148053			
Rev.No	4			

AYVAZ

Toleransı ve standartı verilmemiş uzunluk ve açı ölçüleri için toleranslar.
Standard and Tolerances For Linear and angular dimensions without individual tolerance indications.

EN 22768-1

ISO 2768-m

Toleransı ve standartı verilmemiş şekil ve konumlar için geometrik toleranslar.
Standard and Geometrical tolerances for features without individual tolerance indications.

EN 22768-2

ISO 2768-K